

SATA Slim

3SE Series

Customer: _____

Customer

Part

Number: _____

Innodisk

Part

Number: _____

Innodisk

Model Name: _____

Date: _____

Innodisk Approver	Customer Approver

**Total Solution For
Industrial Flash Storage**

Table of contents

LIST OF FIGURES	6
1. PRODUCT OVERVIEW	7
1.1 INTRODUCTION OF INNODISK SATA SLIM 3SE.....	7
1.2 PRODUCT VIEW AND MODELS	7
1.3 SATA INTERFACE.....	8
1.4 CAPACITY	8
1.5 MO-297 FORM FACTOR.....	8
2. PRODUCT SPECIFICATIONS	9
2.1 CAPACITY AND DEVICE PARAMETERS.....	9
2.2 PERFORMANCE	9
2.3 ELECTRICAL SPECIFICATIONS	9
2.3.1 Power Requirement.....	9
2.3.2 Power Consumption	10
2.4 ENVIRONMENTAL SPECIFICATIONS	10
2.4.1 Temperature Ranges	10
2.4.2 Humidity.....	10
2.4.3 Shock and Vibration	10
2.4.4 Mean Time between Failures (MTBF)	10
2.5 CE AND FCC COMPATIBILITY	11
2.6 RoHS COMPLIANCE	11
2.7 RELIABILITY	11
2.8 TRANSFER MODE	11
2.9 PIN ASSIGNMENT	11
2.10 MECHANICAL DIMENSIONS.....	13
2.11 ASSEMBLY WEIGHT	13
2.12 SEEK TIME	13
2.13 HOT PLUG.....	13
2.14 NAND FLASH MEMORY.....	13
3.1 OVERVIEW.....	14
3.2 SATA III CONTROLLER	14
3.3 ERROR DETECTION AND CORRECTION.....	14
3.4 WEAR-LEVELING	15
3.5 BAD BLOCKS MANAGEMENT	15
3.6 POWER CYCLING	15
3.7 GARBAGE COLLECTION.....	15
4. INSTALLATION REQUIREMENTS	16
4.1 SATA SLIM 3SE PIN DIRECTIONS.....	16

4.2 ELECTRICAL CONNECTIONS FOR SATA SLIM 3SE 16

4.3 DEVICE DRIVE 16

5. PART NUMBER RULE17

REVISION HISTORY

Revision	Description	Date
Preliminary	First Released	September, 2013

List of Tables

TABLE 1: DEVICE PARAMETERS	9
TABLE 2: PERFORMANCE	9
TABLE 3: INNODISK SATA SLIM 3SE POWER REQUIREMENT	9
TABLE 4: POWER CONSUMPTION	10
TABLE 5: TEMPERATURE RANGE FOR SATA SLIM 3SE	10
TABLE 6: SHOCK/VIBRATION TESTING FOR SATA SLIM 3SE	10
TABLE 7: SATA SLIM 3SE MTBF	11
TABLE 8: INNODISK SATA SLIM 3SE PIN ASSIGNMENT	12

List of Figures

FIGURE 1: INNODISK SATA SLIM 3SE	7
FIGURE 2: INNODISK SATA SLIM 3SE BLOCK DIAGRAM.....	14
FIGURE 3: SIGNAL SEGMENT AND POWER SEGMENT.....	16

1. Product Overview

1.1 Introduction of Innodisk SATA Slim 3SE

Innodisk SATA Slim 3SE is designed with standard SATA interface (7+15 SATA connector), which could support most platforms with standard SATA port. Besides, with its smaller dimension, SATA Slim 3SE is an alternative solution of 2.5" SSD for those embedded system that may have mechanical and space concerns. SATA Slim 3SE operates under SATA III (6.0Gb/s) protocol with good performance.

SATA Slim 3SE is also suitable in industrial field. It effectively reduces the booting time of operation system and the power consumption is less than hard disk drive (HDD). SATA Slim 3SE is compatible with ATA protocol, no additional drivers are required, and the SATA Slim 3SE can be configured as a boot device or data storage device.

1.2 Product View and Models

Innodisk SATA Slim 3SE is available in follow capacities within SLC flash ICs.

- | | |
|------------------------------------|-------------------------------------|
| SATA Slim 3SE 04GB | SATA Slim 3SE 32GB |
| SATA Slim 3SE 08GB | SATA Slim 3SE 64GB |
| SATA Slim 3SE 16GB | SATA Slim 3SE 128GB |



Figure 1: Innodisk SATA Slim 3SE

1.3 SATA Interface

Innodisk SATA Slim 3SE support SATA III interface, and compliant with Serial ATA Gen 1, Gen 2 and Gen 3 specification (Gen 3 supports 1.5Gbps /3.0Gbps/6.0Gbps data rate). SATA connector uses a 7-pin signal segment and a 15-pin power segment.

1.4 Capacity

Innodisk SATA Slim 3SE provides unformatted 4GB, 8GB, 16GB, 32GB, 64GB and 128GB capacities within SLC Flash IC.

1.5 MO-297 Form Factor

SATA Slim 3SE has a compact design 54.0mm (W) x 39.0mm (L) x 4.0mm (H) without metal material case, and is easy for installation.

2. Product Specifications

2.1 Capacity and Device Parameters

Innodisk SATA Slim 3SE device parameters are shown in Table 1.

Table 1: Device parameters

Capacity	LBA	Cylinders	Heads	Sectors	User Capacity(MB)
4GB	7835184	7773	16	63	3,826
8GB	15649200	15255	16	63	7,641
16GB	31277232	16383	16	63	15,272
32GB	62533296	16383	16	63	30,533
64GB	125045424	16383	16	63	61,057
128GB	250069680	16383	16	63	122,104

2.2 Performance

Burst Transfer Rate: 3.0Gbps

Table 2: Performance

Capacity	4GB	8GB	16GB	32GB	64GB	128GB
Sequential Read (max.)	250 MB/sec	400 MB/sec	400 MB/sec	460 MB/sec	470 MB/sec	470 MB/sec
Sequential Write (max.)	50 MB/sec	110 MB/sec	130 MB/sec	230 MB/sec	360 MB/sec	370 MB/sec

Note: Base on CrystalDiskMark 3.01 with file size 1000MB

2.3 Electrical Specifications

2.3.1 Power Requirement

Table 3: Innodisk SATA Slim 3SE Power Requirement

Item	Symbol	Rating	Unit
Input voltage	V _{IN}	+5 DC +- 5%	V

2.3.2 Power Consumption

Table 4: Power Consumption

Mode	Power Consumption (mA)
Read	220 (max.)
Write	220 (max.)
Idle	184 (max.)

* Target: SATA Slim 3SE 128GB

2.4 Environmental Specifications

2.4.1 Temperature Ranges

Table 5: Temperature range for SATA Slim 3SE

Temperature	Range
Operating	Standard Grade: 0°C to +70°C
	Industrial Grade: -40°C to +85°C
Storage	-55°C to +95°C

2.4.2 Humidity

Relative Humidity: 10-95%, non-condensing

2.4.3 Shock and Vibration

Table 6: Shock/Vibration Testing for SATA Slim 3SE

Reliability	Test Conditions	Reference Standards
Vibration	7 Hz to 2K Hz, 20G, 3 axes	IEC 68-2-6
Mechanical Shock	Duration: 0.5ms, 1500 G, 3 axes	IEC 68-2-27

2.4.4 Mean Time between Failures (MTBF)

Table 7 summarizes the MTBF prediction results for various SATA Slim 3SE configurations. The analysis was performed using a RAM Commander™ failure rate prediction.

- **Failure Rate:** The total number of failures within an item population, divided by the total number of life units expended by that population, during a particular measurement interval under stated condition.
- **Mean Time between Failures (MTBF):** A basic measure of reliability for repairable items:

The mean number of life units during which all parts of the item perform within their specified limits, during a particular measurement interval under stated conditions.

Table 7: SATA Slim 3SE MTBF

Product	Condition	MTBF (Hours)
Innodisk SATA Slim 3SE	Telcordia SR-332 GB, 25°C	>3,000,000

2.5 CE and FCC Compatibility

SATA Slim 3SE conforms to CE and FCC requirements.

2.6 RoHS Compliance

SATA Slim 3SE is fully compliant with RoHS directive.

2.7 Reliability

Parameter	Value
Read Cycles	Unlimited Read Cycles
Wear-Leveling Algorithm	Support
Bad Blocks Management	Support
Error Correct Code	Support
Flash endurance	100,000 P/E cycles
TBW(Sequential Write)	
4GB	360
8GB	720
16GB	1440
32GB	2880
64GB	5760
128GB	11520

2.8 Transfer Mode

SATA Slim 3SE support following transfer mode:

Serial ATA III 6.0Gbps

Serial ATA II 3.0Gbps

Serial ATA I 1.5Gbps

2.9 Pin Assignment

Innodisk SATA Slim 3SE uses a standard SATA pin-out. See Table 8 for SATA Slim 3SE pin assignment.

Table 8: Innodisk SATA Slim 3SE Pin Assignment

Name	Type	Description
S1	GND	NA
S2	A+	Differential Signal Pair A
S3	A-	
S4	GND	NA
S5	B-	Differential Signal Pair B
S6	B+	
S7	GND	NA
Key and Spacing separate signal and power segments		
P1	NC	NA
P2	NC	NA
P3	NC	NA
P4	GND	NA
P5	GND	NA
P6	GND	NA
P7	V5	5V Power, Pre-Charge
P8	V5	5V Power
P9	V5	5V Power
P10	GND	NA
P11	DAS/DSS	Device Activity Signal / Disable Staggered
P12	GND	NA
P13	NC	NA
P14	NC	NA
P15	NC	NA

2.10 Mechanical Dimensions

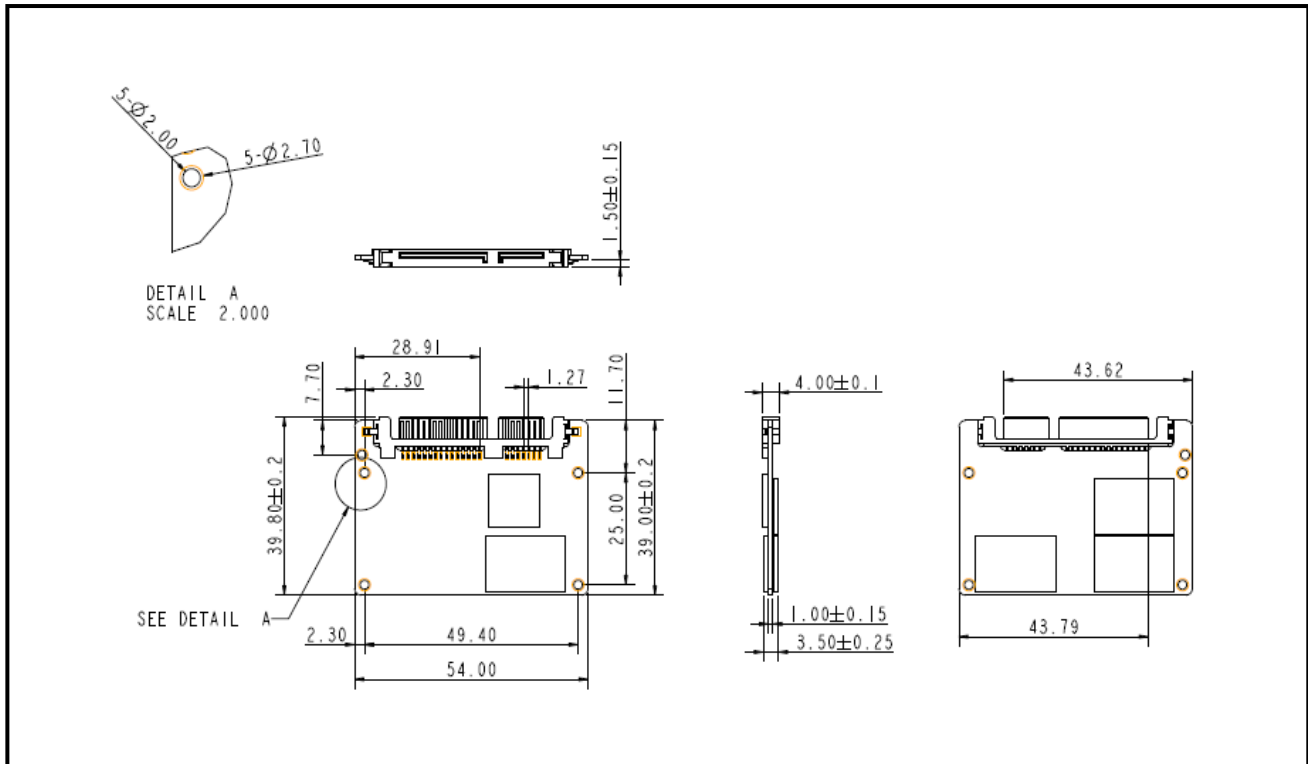

2.11 Assembly Weight

An Innodisk SATA Slim 3SE within SLC flash ICs, 16GB's weight is 9 grams approx. The total weight of SSD will be less than 12 grams.

2.12 Seek Time

Innodisk SATA Slim 3SE is not a magnetic rotating design. There is no seek or rotational latency required.

2.13 Hot Plug

The SSD support hot plug function and can be removed or plugged-in during operation. User has to avoid hot plugging the SSD which is configured as boot device and installed operation system.

Surprise hot plug : The insertion of a SATA device into a backplane (combine signal and power) that has power present. The device powers up and initiates an OOB sequence.

Surprise hot removal: The removal of a SATA device from a powered backplane, without first being placed in a quiescent state.

2.14 NAND Flash Memory

Innodisk SATA Slim 3SE uses Single Level Cell (SLC) NAND flash memory, which is non-volatility, high reliability which has 100,000 program/erase times and high speed memory storage.

3. Theory of Operation

3.1 Overview

Figure 2 shows the operation of Innodisk SATA Slim 3SE from the system level, including the major hardware blocks.

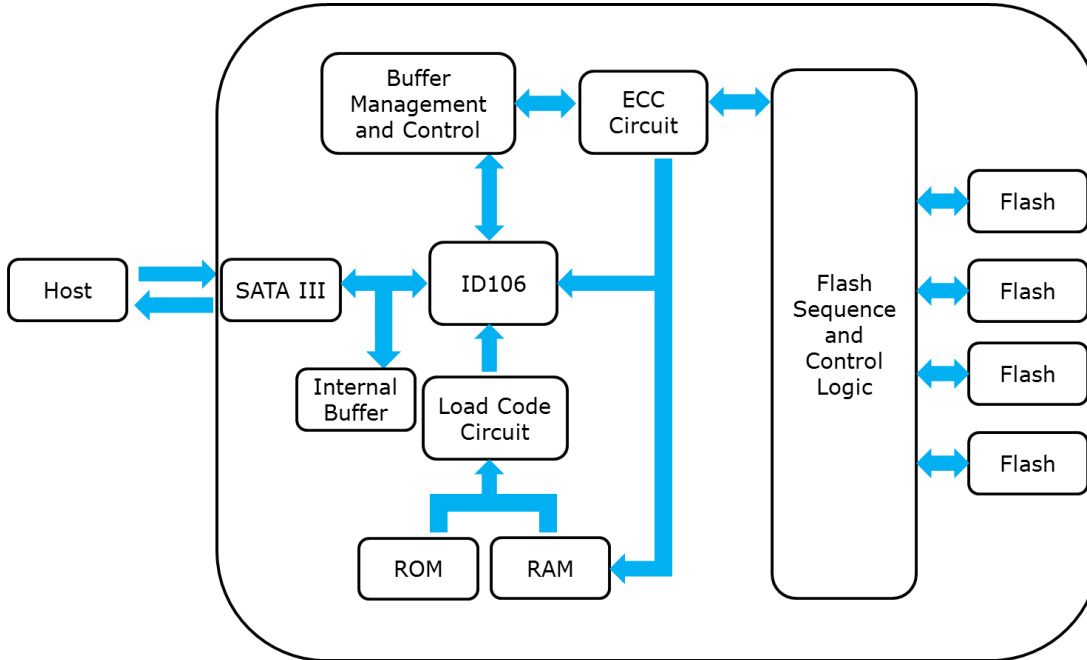

Figure 2: Innodisk SATA Slim 3SE Block Diagram

Innodisk SATA Slim 3SE integrates a SATA III controller and NAND flash memories. Communication with the host occurs through the host interface, using the standard ATA protocol. Communication with the flash device(s) occurs through the flash interface.

3.2 SATA III Controller

Innodisk SATA Slim 3SE is designed with ID 106, a SATA III 6.0Gbps (Gen. 3) controller. The Serial ATA physical, link and transport layers are compliant with Serial ATA Gen 1, Gen 2 and Gen 3 specification (Gen 3 supports 1.5Gbps/3.0Gbps/6.0Gbps data rate). The controller has 4 channels for flash interface.

3.3 Error Detection and Correction

Highly sophisticated Error Correction Code algorithms are implemented. The ECC unit consists of the Parity Unit (parity-byte generation) and the Syndrome Unit (syndrome-byte computation). This unit implements an algorithm that can correct 40 bits per 1024 bytes in an ECC block. Code-byte generation during write operations, as well as error detection during read operation, is implemented on the fly without any speed penalties.

3.4 Wear-Leveling

Flash memory can be erased within a limited number of times. This number is called the **erase cycle limit** or **write endurance limit** and is defined by the flash array vendor. The erase cycle limit applies to each individual erase block in the flash device.

Innodisk SATA Slim 3SE uses a static wear-leveling algorithm to ensure that consecutive writes of a specific sector are not written physically to the same page/block in the flash. This spreads flash media usage evenly across all pages, thereby extending flash lifetime.

3.5 Bad Blocks Management

Bad Blocks are blocks that contain one or more invalid bits whose reliability are not guaranteed. The Bad Blocks may be presented while the SSD is shipped, or may develop during the life time of the SSD. When the Bad Blocks is detected, it will be flagged, and not be used anymore. The SSD implement Bad Blocks management, Bad Blocks replacement, Error Correct Code to avoid data error occurred. The functions will be enabled automatically to transfer data from Bad Blocks to spare blocks, and correct error bit.

3.6 Power Cycling

Innodisk's power cycling management is a comprehensive data protection mechanism that functions before and after a sudden power outage to SSD. Low-power detection terminates data writing before an abnormal power-off, while table-remapping after power-on deletes corrupt data and maintains data integrity. Innodisk's power cycling provides effective power cycling management, preventing data stored in flash from degrading with use.

3.7 Garbage Collection

Garbage collection is used to maintain data consistency and perform continual data cleansing on SSDs. It runs as a background process, freeing up valuable controller resources while sorting good data into available blocks, and deleting bad blocks. It also significantly reduces write operations to the drive, thereby increasing the SSD's speed and lifespan.

4. Installation Requirements

4.1 SATA Slim 3SE Pin Directions

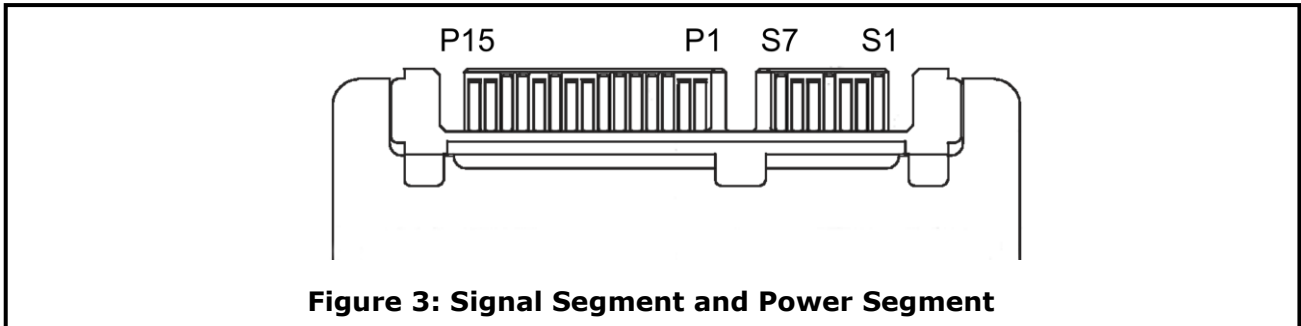

4.2 Electrical Connections for SATA Slim 3SE

A Serial ATA device may be either directly connected to a host or connected to a host through a cable. For connection via cable, the cable should be no longer than 1meter. The SATA interface has a separate connector for the power supply. Please refer to the pin description for further details.

4.3 Device Drive

No additional device drives are required. Innodisk SATA Slim 3SE can be configured as a boot device.

5. Part Number Rule

CODE	1	2	3	4	5	6	7	8	9	10	11	12	13	14	15	16	17	18	19	20
	D	E	S	L	M	-	3	2	G	D	0	6	S	C	A	Q	B	-	X	X
Description	Disk	SATA Slim 3SE					Capacity			Category			Flash Mode	Operation Temp.	Internal Control	CH.	Flash	-	Customized Code	
Definition																				
Code 1st (Disk)												Code 13th (Flash Mode)								
D : Disk												S: Synchronous flash								
Code 2nd ~ 5th (Form Factor)												Code 14th (Operation Temperature)								
ESLM: SATA Slim 3SE												C: Standard Grade (0°C ~ +70°C)								
Code 7th ~9th (Capacity)												Code 15th (Internal control)								
04G: 4GB												Code 16th (Channel of data transfer)								
08G: 8GB																				
16G: 16GB												D: Dual Channels								
32G: 32GB												Q: Quad Channels								
64G: 64GB												Code 17th (Flash Type)								
A28: 128GB												B: Toshiba SLC								
Code 10th ~12th (Series)												Code 19th~20th (Customized Code)								
D06: ID106																				

Appendix

CE/FCC (TBD)